

Spherical roller bearings, cylindrical and tapered bore

Principal dimensions			Basic load ratings		Speed ratings	Limiting speed	Designation
d	D	B	dynamic C	static C0	Reference speed		* SKF Explorer bearing
mm			kN		r/min		-
110	200	69,8	626	765	2200	3200	23222 CCK/W33 *

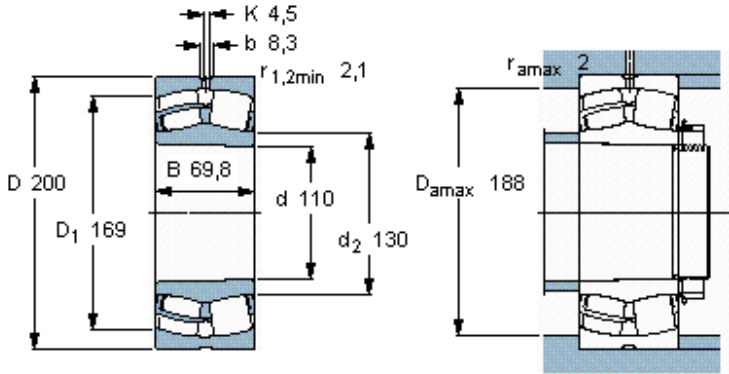

Tapered bore, taper
1: 12

- Calculation factors**
- e 0,33
 - Y₁ 2
 - Y₂ 3
 - Y₀ 2